

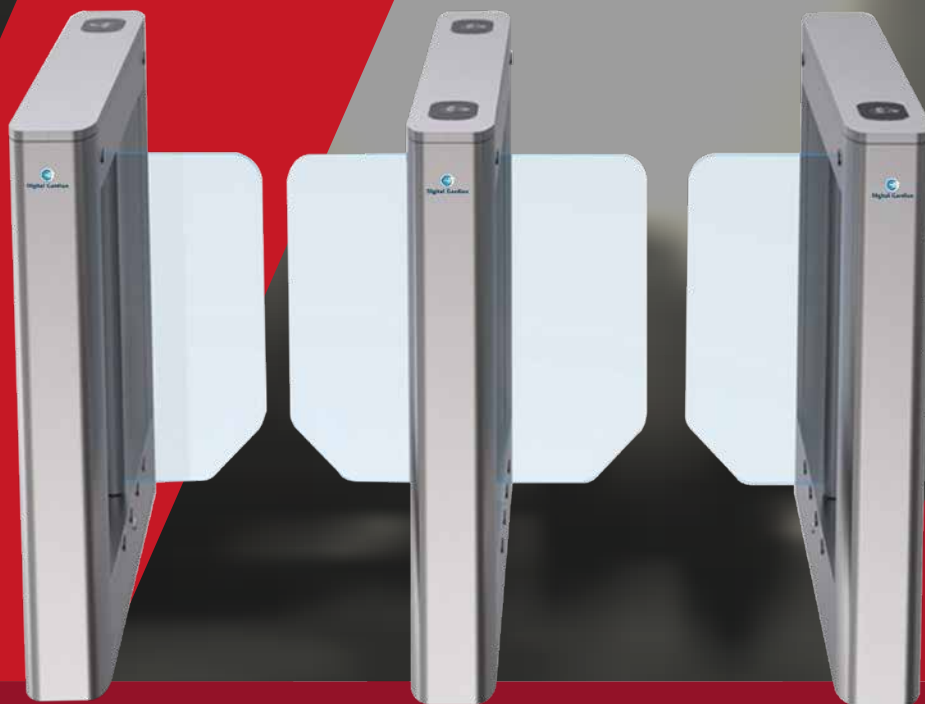

Digital Guardian

SPEED GATE



Model No: VB8905-0



Dimensions

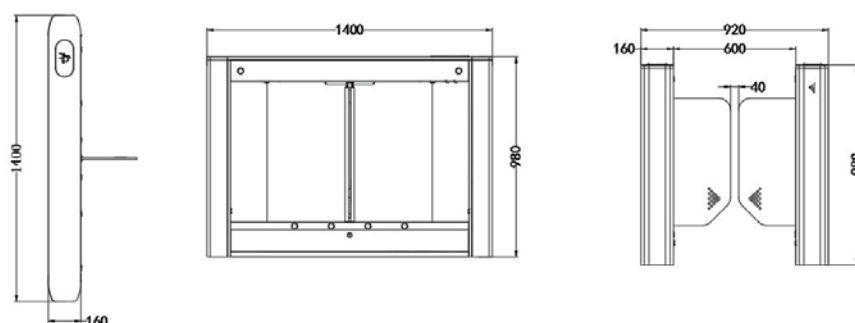



Features

- Reasonable and reliable design, low noise, stable operation, and long service life
- Equipped with automatic opening function of power outage door wings, meeting the needs of fire exits
- Equipped with anti tailgating and anti anti backtracking capabilities
- Swipe the card to set the "with memory" or "without memory" function
- It has an automatic reset function, which means that after obtaining the permission to pass the gate, if there is no pass within the set time, the gate will automatically return to the locked state
- Equipped with infrared anti pinch and rebound function when encountering obstacles (anti pinch function is available when the baffle is running)
- Compatible with recognition methods such as IC, ID card scanning, and facial recognition
- It can provide two working modes: normally open or normally closed
- It has multiple working modes to choose from, including bidirectional card reading and simultaneous card reading

Technical Specification

Dimension	1400*160*980mm
Channel width	600-1100mm
Net weight	45kg
Material Science	Top cover 1.2mm+body 0.9mm 304 brushed plate
door plank	10mm transparent acrylic
a partition	8mm transparent acrylic
Movement	Brushless swing brake integrated movement
infra-red	Mirror metal circular 6 pairs
a sensor	NA
indicator light	Three color light panel+three color light strip
electric machinery	Fengdun DC brushless 90K 30W
Power Supply	24V 150W
control	1V2 brushless board+sub controller board



Case Presentation



Mailing Address

VOSTOK Trading L.L.C,
304, 3rd Floor, Al Tawhidi Building,
Khaleed Bin Waleed Road,
P.O. Box: 27106 - Dubai,
UNITED ARAB EMIRATES.

Contact Details

Tel : (+971 4) 3558816

Fax : (+971 4) 3558817

Email : sales1@digitalgardian.com /
sales2@digitalgardian.com /