



Digital Guardian

Swing Gate





Digital Gardian

Model No: DH-VE9808

FEATURES & FUNCTIONS

Reasonable and reliable design

Operation: Smooth & Low Noise

Long Service Life

Functions of anti-tail, anti-reverse pass.

Automatic reset function.

Working modes: Two-way & One-way card reading.

Opening Doors Automatically Under Power-off state.

Compatible with IC, ID Card, Scanning and Face Recognition, etc.

Two models of operation are available: open or close.

PARAMETERS

Material	Cold rolling steel with painting 1.5mm
size	600*130*980 mm
Sensor Pairs	4
Pass Rate	35 p/m
Flap Type	600-900mm
Input Voltage	100~240 V
Motor Type	24V DC Brushless motor
Environment	-20~+70C
Motor Power	55W
Input Signal	Dry Contact/RS485

PRODUCT SIZE

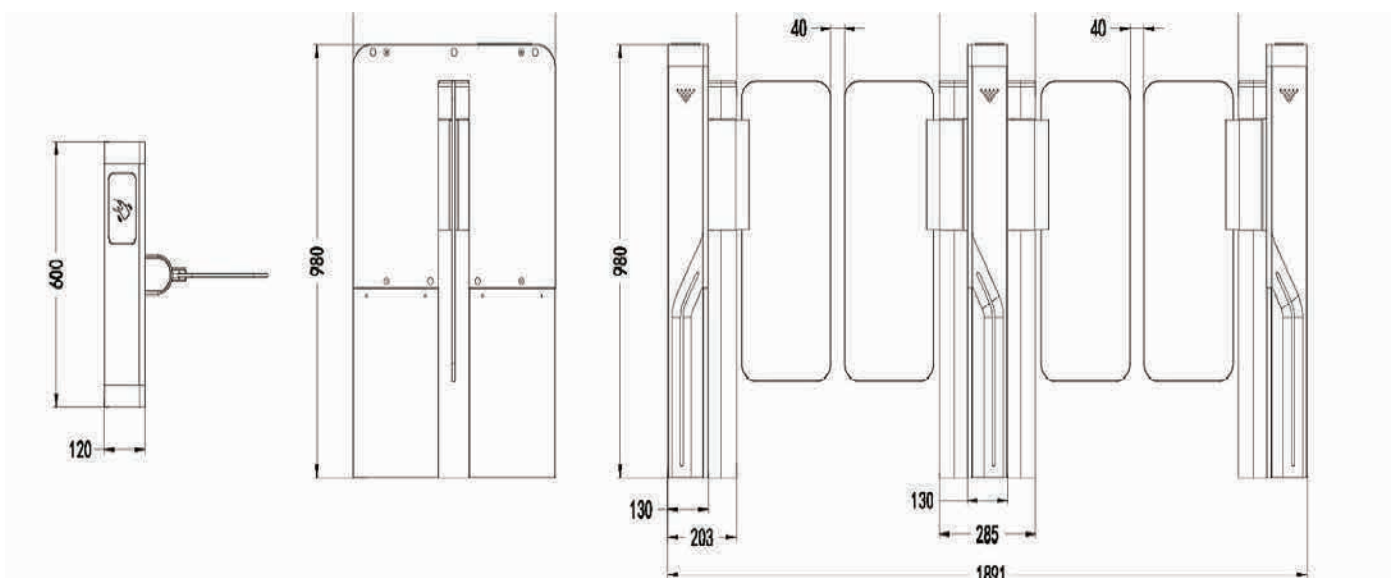

Mailing Address

VOSTOK Trading L.L.C,
304, 3rd Floor, Al Tawhidi Building,
Khaleed Bin Waleed Road,
P.O. Box: 27106 - Dubai,
UNITED ARAB EMIRATES.

Contact Details

Tel : (+971 4) 3558816
Fax : (+971 4) 3558817
Email : sales1@digitalgardian.com /
sales2@digitalgardian.com /